



**sunmix**  
NEW GENERATION MACHINES

SPIRAL MIXER  
SMALL LINE



SUN6



SUN10



SUN15



SUN20

## I

### CARATTERISTICHE TECNICHE:

- Capacità di impasto da 6 a 20 kg.
- Vasca, spirale, piantone in acciaio inox ad alta resistenza.
- Riparo in acciaio su tutta la gamma.
- Trasmissione su cuscinetti a sfera pre-lubrificati.
- Motore monofase con inverter.
- Velocità 70/210 rpm.
- Verniciatura con polveri epossidiche atossiche per alimenti.
- Impianti elettrici e dispositivi di sicurezza secondo le norme CE.
- Colori disponibili:  
**SUN6/10/15**  
 bianco/rosso/giallo/arancio/grigio/grigio scuro  
**SUN20**  
 grigio/bianco/rosso

### OPTIONAL:

- Timer 30min
- Inversione di vasca.
- Luci per illuminare l'impasto.
- 300 giri/minuto.
- Carrello.

## EN

### TECHNICAL SPECIFICATIONS:

- Mixing capacity from 6 to 20 kg.
- High resistance stainless steel bowl, spiral arm and breaking bar.
- Stainless steel safety guard.
- Pre-lubricated ball bearing transmission.
- Single phase motor with inverter.
- Speed 70/210 rpm.
- Non-toxic powdered epoxy certified coating.
- Electrical system and safety devices realised in accordance with CE regulation.
- Available colors:  
**SUN6/10/15**  
 white/red/yellow/orange/grey/dark grey.  
**SUN20**  
 grey/white/red.

### OPTIONAL:

- Timer.
- Reverse
- Lights to illuminate dough.
- 300 rpm (spiral)
- Trolley.

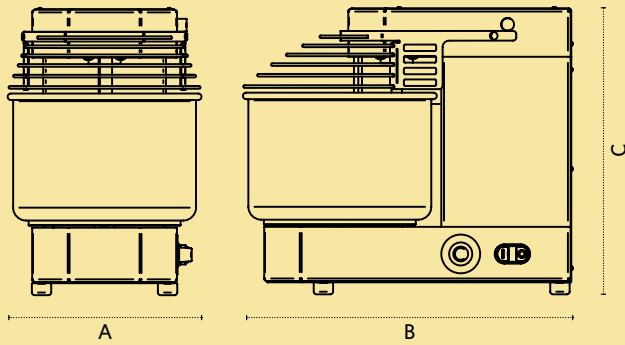

DATI TECNICI  
 TECHNICAL SPECIFICATIONS  
 CARACTERISTIQUES TECHNIQUES  
 DATOS TÉCNICOS



Modello Model Modèle Modelo	Capacità impasto Dough capacity Capacité de pâte Capacidad de masa	Capacità farina Flour capacity Capacité de farine Capacidad de harina	Volume vasca Bowl volume Volume de la cuve Volumen cuva	Potenza motore Motor power Puissance du moteur Potencia motore	Volt Volt Volt Volt	Velocità Speed Vitesse Velocidad	Peso Weight Poids Peso	Dimensioni / Dimensions Dimensions / Dimensiones		
	kg	kg	lt	kw			kg	A cm	B cm	C cm
<b>SUN6</b>	6	3,5	8	0.37	230/50/1		31	28	48	39
<b>SUN10</b>	10	6	12	0.37	230/50/1		35	30	51	45
<b>SUN15</b>	15	8	18	0.55	230/50/1		37	34	55	45
<b>SUN20</b>	20	12	25	1.1	230/50/1		50	40	63	55

\*Capacità di impasto calcolata su un'idratazione del 60% / \*Dough capacity calculated on a 60% hydration / \*Capacité de pâte calculée sur 60% d'hydratation / \*Capacidad de masa calculada sobre una hidratación del 60%

**F**

**CARACTÉRISTIQUES TECHNIQUES:**

- Capacité de pâte kg 6/20.
- Cuve, spirale, soc diviseur en acier inoxydable hautement résistant.
- Grille de protection en acier inoxydable.
- Système de transmission à roulements à bille lubrifiés par bain d'huile.
- Moteur monophasé avec inverter.
- Vitesse 70/210 rpm.
- Peinture réalisée en poudre époxy spéciale alimentaire.
- Installation électrique et dispositifs de sécurité conformes aux normes européennes.
- Couleurs disponibles :  
**SUN6/10/15**  
 blanc/rouge/jaune/orange/gris/gris foncé.  
**SUN20**  
 gris/blanc/rouge.

**OPTIONAL:**

- Minuteur.
- Sens Inverse.
- Lumières pour éclairer la pâte.
- 300 rpm.
- Chariot.

**ES**

**CARACTERÍSTICAS TÉCNICAS:**

- Capacidad de amasado de 6 a 20 kg.
- Cueva, espiral, protección de acero inoxidable de alta resistencia.
- Protección de cuva de acero en toda la gama.
- Transmisión mediante cojinetes de esfera prelubricados.
- Motor monofásico con inversor.
- Velocidad 70/210 rpm.
- Pintado con polvos epoxídicos atóxicos para alimentos.
- Instalación eléctrica y dispositivos de seguridad según normas CE.
- Colores disponibles:  
**SUN6/10/15**  
 blanco/rojo/amarillo/naranja/gris/gris oscuro.  
**SUN20**  
 gris/blanco/rojo.

**OPTIONAL**

- Temporizador.
- Inversion.
- Luces para iluminar la masa.
- 300 rpm.
- Carrito.

CE



**Sunmix Srl**  
Via Lago di Vico, 4 - 36015 Schio (VI) Italy  
Tel. +39 0445 640559 - [info@sunmix.it](mailto:info@sunmix.it)  
P. IVA / C.F. 04250510247 - [www.sunmix.it](http://www.sunmix.it)

